



# OPERATING INSTRUCTIONS

## MEMFLO™ MFAM METAL BODIED FLOW METER



# TABLE OF CONTENTS

Introduction .....	3
Safety Precautions.....	3
Specifications .....	4
Dimensions.....	4-5
Installation & Setup.....	6
Disassembly .....	7
Reading Flow.....	8
Maintenance.....	8
Inspection & Cleaning.....	8
Assembly.....	8-9
Replacement Parts.....	10
Calibration Traceability.....	10
Flow Rate Selection .....	10
MFAM Flow Meter Parts Detail .....	11
Temperature Limits.....	12
Specific Gravity or Density .....	12
Viscosity Considerations .....	12
Capacity Tables .....	13-14
Operating Limits.....	15
Troubleshooting.....	15-16
Ordering Information .....	17
Return Policy .....	18
Warranty Policy.....	18

## Introduction

*Please read carefully! No liability can be accepted for damage caused by improper use or installation of the MEMFlo SupraFlo MFAM Flow Meter.*

MEMFlo™ MFAM All Metal Flow Meters are simple, accurate, meters for use in a wide range of industrial liquid and gas applications. These meters have an excellent tolerance to suspended solids and measure flow to one percent accuracy. With an all metal design, these meters are ideal for high pressures, high temperatures, steam, dirty fluids, and harsh service environments. MEMFlo All Metal Flow Meters use an internal magnet to carry an external indicator in a non-wetted enclosure. And they can be supplied with the MFT2™ 2-Wire Transmitters for flow rate and total. Additionally, these meters can be supplied with a high temperature indicator option for service up to 600°F.

## Safety Precautions

If you are unsure of the suitability of a MFAM Flow Meter for your installation, please consult your FLO-CORP representative for further information.

**NOTE: REMOVE ALL PACKING INSERTS BEFORE OPERATING FLOW METER.**

## Authorized Personnel

All operations described in this operating instructions manual must be carried out only by trained specialist personnel authorized by the plant operator. During work on and with the device the required personal protection equipment must always be worn.

## Warning about misuse

Inappropriate or incorrect use of the instrument can give rise to application-specific hazards , e.g. vessel over fill or damage to system components through incorrect mounting or adjustment.

## General Safety Instructions

The user must take note of the safety instructions in this operating instructions manual , the country specific installation standards as well as all prevailing safety regulations and accident prevention rules. The instrument must only be operated in a technically flawless and reliable condition . The operator is responsible for trouble-free operation of the instrument. During the entire duration of use, the user is obliged to determine the compliance of the required occupational safety measures with the current valid rules and regulations and also take note of new regulations.

## Disclaimer

The information contained in this document is subject to change without notice. FLO-CORP makes no representations or warranties with respect to the contents hereof and specifically disclaims any implied warranties of merchantability or fitness for a particular purpose.

## SPECIFICATIONS

<b>Accuracy</b>	± 1% of 100% flow rate
<b>Repeatability</b>	1/2" to 1-1/2": +/- 1/4% of indicated flow rate 2" to 4": +/- 1/2% of indicated flow rate
<b>Rangeability</b>	30 to 1 average
<b>Materials</b>	1/2" to 2" Small Body: T-316 Stainless Steel 2" to 4" Large Body: Zinc Phosphate, Xylan 1052 coated steel with all stainless internals

<b>Pressure Rating</b>	Up to 1000 psig
<b>Temperature Rating</b>	Up to 600°F (pressure ratings decrease at higher temperatures).
<b>O-Rings</b>	Buna N standard; Viton, Ethylene-Propylene (EPR), Silicone, Neoprene, Teflon, Geothermal EPR (600° steam), and Kalrez optional.
<b>Scales</b>	Standard direct reading (GPM or LPM Liquid, Sp. Gr. = 1.00 or SCFM Dry Air @ 100 psig, 70°F.) or percentage scale. Special scales for other flow units or media conditions, or mylar scales for corrosive environments are available. Scale length is approximately 3.2" for small bodies (1/2" to 2") and 5.2" for large bodies (2" to 4").

## DIMENSIONS

### Small Body

*Note: Please Consult Factory for Special Requirements*

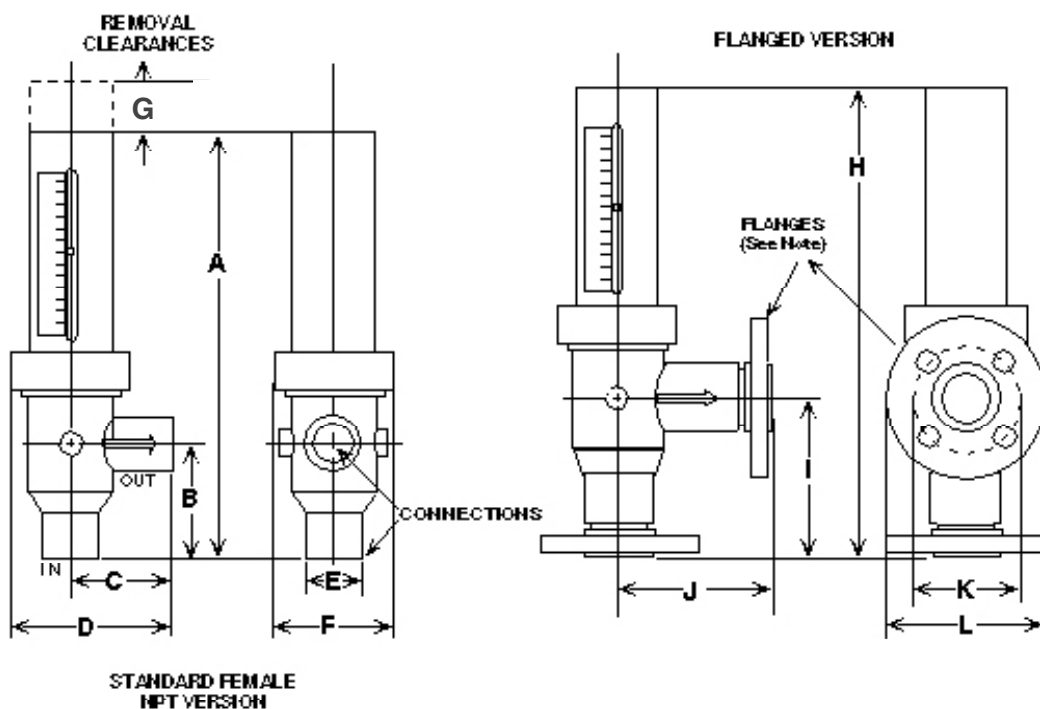

BODY MATERIAL	A	B	C	D	E	F	G	Female NPT
All Stainless	10.76	2.81	2.68	4.03	1.50	2.75	3.00	Up to 3/4"
All Stainless	15.64	4.53	3.71	5.70	2.48	4.01	5.00	Up to 2"

BODY MATERIAL	H	I	J	K	L	150lb Flange
All Stainless	11.64	5.92	3.56	2.75	3.88	Up to 3/4"
All Stainless	17.03	5.92	4.96	3.88	5.00	Up to 2"

**Note:** All dimensions are in inches, with a tolerance of ±0.03" on threaded models, ±0.20" on flanged units.

### Large Body

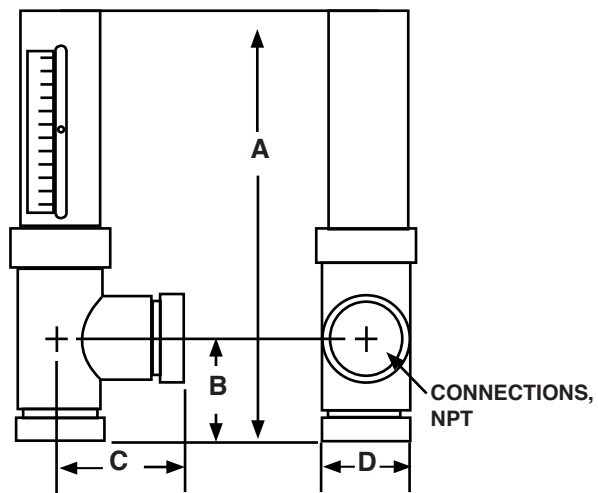

BODY & MEASURING TUBE DESCRIPTION	A	B	C	D	E	Female NPT
Stainless	20.23	6.38	5.38	3.63	NA	2"
Stainless	20.85	6.38	5.38	3.36	NA	2 1/2"
Stainless (150 GPM/1750 SCFM)	22.35	7.50	6.00	4.25	NA	3"
Stainless (200 GPM/2300 SCFM)	25.35	7.88	6.38	4.50	NA	
Stainless	26.85	8.63	7.13	5.56	NA	4"

BODY & MEASURING TUBE DESCRIPTION	A	B	C	D	E	150lb Flange
Stainless	20.73	6.28	6.88	6.00	4.75	2"
Stainless	21.35	6.88	6.88	7.00	5.50	2 1/2"
Stainless (150 GPM/1750 SCFM)	22.60	7.75	7.75	7.50	6.00	3"
Stainless (200 GPM/2300 SCFM)	25.60	8.13	8.13	7.50	6.00	
Stainless	28.10	9.88	9.88	9.00	7.50	4"

**Note:** All dimensions are in inches,  $\pm 0.05"$ . Subject to change without prior notice.

## Installation and Setup

**RECOMMENDED PIPING:** FLO-CORP's flow meters generally have no special straight run or other piping requirements. Restrictive valves, reducer bushings, elbows, and other devices that might cause contraction of the fluid stream or severe turbulence should not be mounted at inlet. A slight effect on meter accuracy may occur at high flow velocities if inlet piping guidelines are violated.

Inlet piping should be the same size as the meter connection. When installing a different pipe size, use standard pipe adapters and come into the meter inlet with a nipple eight diameters long of the same size for greatest accuracy. Control valves should be mounted on the outlet side of the meter. The use of a three valve manifold around the meter is suggested as it allows uninterrupted process flow while the meter is being cleaned.

**PREPARATION:** FLO-CORP's flow meters are ready to install as-is, although the measuring tube may need to be reoriented so the the scale is visible after installation.

**PLUMBING-IN:** While the flow meters should be vertical, exact plumbness is not necessary. A general rule is that if the meter appears plumb, it is close enough (even if off by 10°, the predictable reading error is usually less than 1%). Pipe should be cut to proper lengths to avoid stress on the meter used. Avoid over-tightening of the flange bolts.

**MEASURING TUBE ROTATION:** On standard MFAM All Metal Flow Meters, the magnet slides out of the carrier at the top of the float assembly. The screw holding the carrier to the float may be loosened to allow rotating the carrier toward the desired scale location. Re-tighten the screw (thread sealant is recommended), replace magnet, and reassemble the meter (see "Assembly"). Verify that the ball indicator has been "captured" by the magnet. If not, rotate the measuring tube (DO NOT twist on the edges of the plastic raceway assembly) until the ball is "grabbed" by the float magnet.

**SURGE CHAMBERS & ACCUMULATORS:** Flow meters are more accurate and less likely to be damaged when the fluid flow is smooth. If the meter must be installed on a line where reciprocating pumps or compressors causing pulsation are used, surge chambers or accumulators are strongly suggested to damp the shock wave.

## Disassembly

It is not necessary to remove the All Metal Flow Meter from the pipeline for cleaning or replacing parts. The body remains plumbed into the pipe, allowing easy service and even installation of different sensing elements to accommodate new flow rates or fluids. Figure 1 shows some of the major components. Step by step disassembly and reassembly instructions and photos are included below.

**CAUTION: BE SURE PRESSURE IS FULLY VENTED AND FLUIDS COMPLETELY DRAINED BEFORE DISASSEMBLING THE FLOWMETER. DISCONNECT POWER TO ELECTRONIC ACCESSORIES. WEAR SAFETY GLASSES AND PROTECTIVE CLOTHING IF THERE IS A CHANCE OF EXPOSURE TO HAZARDOUS FLUIDS!**

**1)** Remove the raceway cover by removing the stainless screw at the top, and lift it up and off the meter. Remove the black phenolic raceway, being careful not to displace the ball indicator. Remove the ball indicator by hand.

**2)** Using a screwdriver, carefully pry the notched end of the spiral retaining ring out of the body groove. Move the screwdriver blade under the ring — the action is very much like putting a key on a key ring. Continue until the entire spiral ring has been removed from the groove (please see photo below).

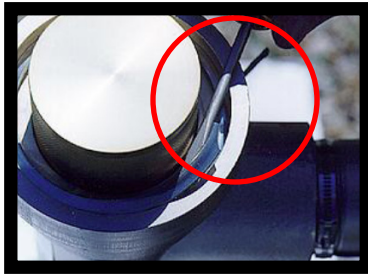

**3)** Using hands only, pull the measuring tube straight up out of the body with a slight twisting motion, lifting it clear of the body and snorkel. The inner flange ring will lift off with the measuring tube.

**4)** Remove the float assembly by lifting it up and away from the snorkel. The core tube assembly may then be lifted out. If stuck, CAREFULLY pry up at the top of the slot with a brass rod, taking care not to damage the body or core tube. The spider ring and O-Ring will come out with the core tube. If the core tube is stuck, try removing the metal spider ring first (please see the photo below).

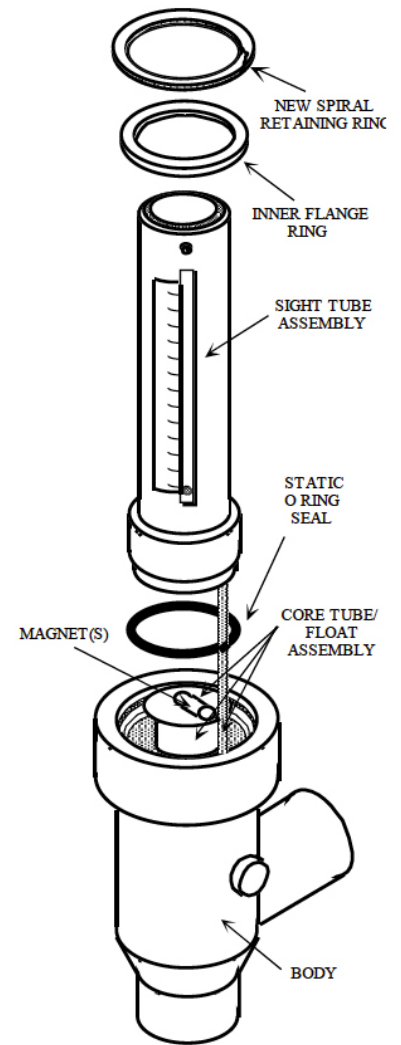

Fig. 1: Partially exploded drawing of the MEMFlo All Metal Flow Meter

## Reading Flow

Read flow directly from the scale as the number nearest the top edge of the float indicator disk.

## Maintenance

Occasional cleaning of the measuring tube and internal sensing elements to assure float visibility and continued accuracy is the only maintenance necessary for MEMFlo flow meters. Frequency will depend on the application – in most cases, an annual cleaning is adequate. It is not necessary to remove the MEMFlo flow meter from the pipeline for cleaning or replacing parts. The body remains plumbed into the pipe, allowing easy service and even installation of different sensing elements to accommodate new flow rates or fluids.

## Inspection and Cleaning

Inspect parts for nicks, scratches, chips, wear and contaminant build-up. The edges of the core tube slot, ID of the core tube, and OD of the piston (largest section at the float assembly bottom) are precision machined. Damage to these areas can destroy the meter's accuracy. Also, inspect the O-Ring, the bottom section of the measuring tube and the inside of the upper body section. Damage to these areas may result in leaking. Clean, rinse, and dry all parts carefully, including the O-Ring, preferably with a mild detergent, water, and a soft cloth or soft tube brush. If solvents are used, make sure they are compatible with meter parts.

## Assembly Instructions

In general, replace all parts in reverse order of disassembly.

- 1)** Place the slotted meter tube into the body, aligning the “key” at the bottom of the tube with the keyslot in the bottom of the body.
- 2)** Place the spider over the meter tube with the “notched” leg over the snorkel tube or guide rod. Slide the spider down to the meter tube's shoulder.
- 3)** Place the meter float in the meter tube, aligning the notch in the indicator disk with the snorkel.
- 4)** Seat the O-Ring on the measuring tube, lubricating it with a small amount of service-compatible silicone grease or petroleum jelly to facilitate replacement.





**5)** Using hands only, press the measuring tube firmly down into the meter body with a twisting motion. Be careful not to rock the measuring tube side to side and bend the snorkel tube/guide inward where it might interfere with float movement. Rotate measuring tube as necessary for scale visibility and/or alignment of the raceway screw.

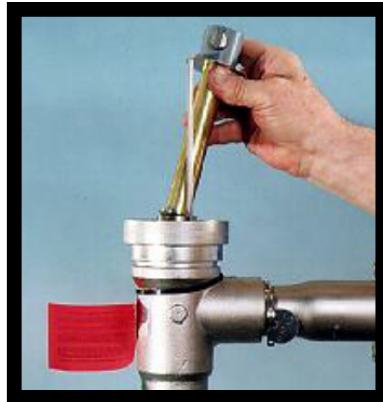

**6)** Slide the inner flange ring over the measuring tube. When properly seated, the top of the flange ring should be flush with the bottom edge of the snap ring groove.

**7)** Separate the coils of the spiral retaining ring, and insert one end into the body groove. Wind the ring into the groove, making sure the ring is properly seated. Then replace the ball indicator (the tip of a screwdriver can be used to help locate the magnet, and replace the raceway and raceway cover).

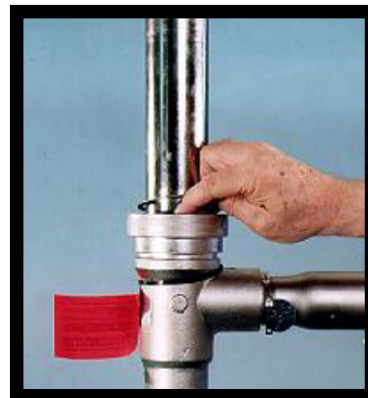

If reassembled correctly, the center of the ball indicator should line up with the scale “zero” (either dotted black or scribed line). If it does not, disassemble the meter completely and carefully reassemble it, making sure the slotted meter tube is completely seated in the body. If new flow internals are used, the scale may have to be remounted on the measuring tube. Depending on the model type, this can be done either by loosening the mounting screw, or reattaching the scale with double sided adhesive (new flow internals are shipped with a new scale).

## Replacement Parts

Because MEMFlo flow meters are custom meters, it is best to stock several complete units as spares to assure availability of replacement parts. Under proper care, there should be no need to stock additional replacement components. If the service or environment is quite harsh, or frequent meter disassembly dictated, spare O-Rings and measuring tubes should be considered.

Otherwise, parts only need to be replaced if damaged. Any visible damage to the entire surface of the O-Ring or measuring tube (particularly from the bottom edge) indicates need for replacement. To insure accuracy, the inside surface of the meter core tube, the slot edges, and the OD of the float piston should be free of nicks, chips, with no visible erosion of any surfaces. If abrasive particles are suspended in the metered fluid, it may be desirable to keep replacement core tube/float assemblies on hand.

FLO-CORP can inspect any suspect parts or recheck calibration. Parts returned should include information regarding the flow application, suspected problem, and who to contact for an authorization on corrective measures. Again, unless the meter is misused, or service is extremely hard, there should be no need for factory recalibration.

To order parts, include the model and serial numbers of the units involved along with a description of the part ordered. If converting the meter to a new application, in addition to the model and serial numbers, SEND FLO-CORP COMPLETE APPLICATION DATA INCLUDING FLUID, MAXIMUM FLOW RATE, MAXIMUM AND OPERATING PRESSURES AND TEMPERATURES AND ANY OTHER APPLICATION PARTICULARS OR FLUID CHARACTERISTIC. This information is essential for FLO-CORP to provide proper items and verify that the new application is within the operating limits of the flow meter.

The only storage or handling requirements for MEMFlo flow meters or parts is to keep them in a reasonably clean location away from excessive heat (over 120°F), chemical or solvent fumes and vapors not compatible with the materials of construction.

## Calibration Traceability

Each MEMFlo flow meter is individually calibrated on test facilities designed and operated according to applicable ASME, ISA, and NIST standards and practices. Individual measuring components of these facilities are certified traceable to NIST, and tandem meter arrangements are employed to continually verify flow data. FLO-CORP's calibrations meet both static and dynamic traceability criteria. For an additional charge, calibrations for  $\pm 1\%$  full scale accuracy can be certified per MIL-STD-45662.

## Flow Rate Selection

It is common practice to select a flow meter placing normal flow at about 75% of full scale. However, the unique "over-read" feature of MEMFlo flow meters allows sizing meters to normal flows in the 85% — 100% range. This provides more precise flow measurement, as meter accuracy is generally a percentage of the 100% scale rating.

# MFAM FLOW METER PARTS DETAIL

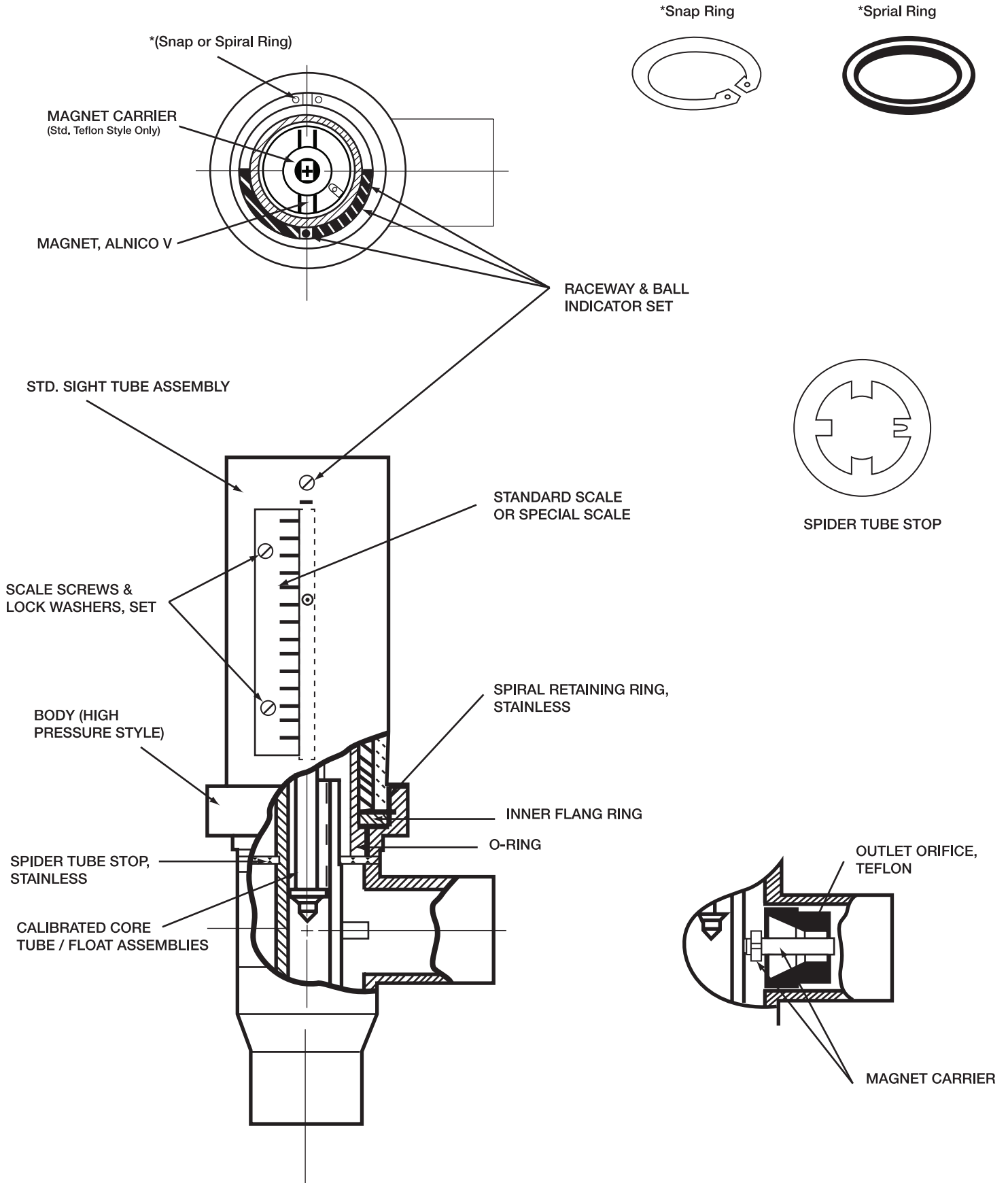

## Temperature Limits

Temperature Limits of Standard MEMFlo Materials

MATERIALS	TEMPERATURE LIMITS
BUNA N	250°F
NEOPRENE	300°F
VITON	475°F
T316 STAINLESS	600°F
CPVC	210°F
EPR (STD.)	250°F
SILICONE	450°F
GEOHERMAL EPR (WATER/STEAM ONLY)	600°F
POLYSULFONE	300°F
KALREZ	575°F
TEFLON	500°F

Float Specific Gravities / Densities

MATERIAL	SPECIFIC GRAVITY OF METER FLOAT	DENSITY OF THE METER FLOAT
Stainless Steel	8.05	501.1

## Specific Gravity or Density

Density, viscosity, and temperature (which affects both density and viscosity) are the key variables affecting accuracy. Pressure effects are negligible, except for safety considerations, since in MEMFlo meter ranges, liquids are generally incompressible. The specific gravity or density of the metered liquid must be known to correctly size the flow meter. This is necessary since the flow indication is proportional to the square root of liquid density. Conversion formulas are provided in this specification.

## Viscosity Considerations

Each MEMFlo flow meter for liquid service has a so-called “Viscosity Immunity Ceiling” (V.I.C.). In most cases, as long as the viscosity of the metered liquid is less than the V.I.C. of the particular flowmeter, accuracy will not be influenced by changes in viscosity. When the viscosity is greater the V.I.C., accuracy is influenced significantly, and the flow meter must be calibrated for the particular fluid. In general, the higher the capacity of the flow meter, the greater (higher V.I.C.) the range of immunity to viscosity variations.

However, the effects of viscosity on a given flow meter are not always predictable. Two apparently similar liquids with comparable densities and viscosities may affect meter calibrations quite differently.

**Small Body**

**Table 1: Flow Meter Capacities, GPM Liquid, Sp. Gr. = 1.00**

CAPACITY DESIGNATOR	FLOW RANGE (GPM LIQUID)	CONNECTION SIZE	OVER-READ FLOW	SCALE INCREMENTS	ΔP, INCHES H2O
00	0.04 - 0.80	04 (1/2")	0.87	0.01	6.5
01	0.06 - 1.20		1.25	0.01	7.5
02	0.08 - 1.64		1.78	0.01	7.5
03	0.10 - 2.60		2.82	0.01	14.2
04	0.15 - 3.80	06 (3/4")	4.40	0.05	17.2
05	0.20 - 5.40		6.10	0.05	17.2
06	0.20 - 7.0		7.90	0.10	22.0
07	0.20 - 10.0		12.0	0.10	22.0
08	0.60 - 14.0	08 (1")	16.0	0.20	40.0
09	0.50 - 23.0		30.0	0.50	75.0
10	0.50 - 11.0	12 (1½")	13.0	0.10	13.8
11	0.70 - 15.0		16.4	0.10	14.8
12	1.00 - 21.0		23.4	0.20	17.5
13	0.50 - 35.0		40.0	0.25	18.5
14	1.00 - 50.0	16 (2")	60.0	0.50	26.0
15	2.00 - 70.0		75.0	0.50	80.0
16	3.00 - 90.0		120.0	1.00	110.0
17	4.00-120		130.0	1.00	130.0

**Table 2: Flow Meter Capacities, SCFM Air, @ 100 PSIG, 70°F.**

CAPACITY DESIGNATOR	FLOW RANGE (SCFM AIR)	CONNECTION SIZE	OVER-READ FLOW	SCALE INCREMENTS	ΔP, INCHES H2O
00	0.50 - 10.20	04 (1/2")	10.9	0.10	2.5
01	0.60 - 14.0		15.0	0.20	3.1
02	1.00 - 20.0		23.0	0.25	3.3
03	1.00 - 26.0		28.0	0.50	3.4
04	1.00 - 35.0	06 (3/4")	39.0	0.50	4.0
05	2.00 - 50.0		55.0	0.50	4.5
06	3.00 - 70.0		75.0	1.00	11.8
07	4.00 - 85.0		100.0	1.00	18.0
08	6.00 - 125.0	08 (1")	140.0	1.00	22.0
09	6.0 - 160.0		180.0	2.00	45.0
10	4.00 - 260.0	12 (1½")	290.0	2.00	93.0
11	1.50 - 25.0		26.5	0.25	1.4
12	1.00 - 31.0		35.0	0.20	1.4
13	2.00 - 40.0		43.0	0.50	1.4
14	3.0 - 70.0	16 (2")	75.0	0.50	4.2
15	4.0 - 100.0		110.0	1.00	7.6
16	5.0 - 140.0		168.0	1.00	7.8
17	5.0 - 175.0		210.0	1.00	7.6
18	6.00 - 250.0	16 (2")	320.0	2.00	7.5
19	2.00 - 310.0		350.0	2.00	12.0
20	7.50 - 390.0		470.0	2.50	22.0
21	10.0 - 510.0		610.0	5.00	40.0
22	35.0 - 750.0		900.0	5.00	70.0
23	20.0 - 1000.0		1200.0	5.00	90.0

**Large Body**

**Table 3: Flow Meter Capacities, GPM Liquid, Sp. Gr. = 1.00, 70°F**

CAPACITY DESIGNATOR	FLOW RANGE (SCFM AIR)	CONNECTION SIZE	ΔP, INCHES H2O
24	3.0 - 70.0	16 (2")	28.5
25	3.0 - 100		32.5
26	6.0 - 150		40.0
27	3.0 - 100	24 (3")	32.5
28	6.0 - 150		40.0
29	10.0 - 200		31.5
30	14.0 - 300		45.5
31	5.0 - 100		20.0
32	10.0 - 200	32 (4")	29.5
33	14.0 - 300		32.0
34	15.0 - 400		65.0
35	20.0 - 500		92.5

**Table 4: Flow Meter Capacities, SCFM Air @ 100 PSIG, 70°F**

CAPACITY DESIGNATOR	FLOW RANGE (SCFM AIR)	CONNECTION SIZE	ΔP, INCHES H2O
24	30.0 - 750	16 (2")	28.5
25	40.0 - 1000		32.5
26	50.0 - 1750		40.0
27	40.0 - 1000	24 (3")	32.5
28	50.0 - 1750		40.0
29	100 - 2300		31.5
30	150 - 3500		45.5
31	50.0 - 1200		20.0
32	100 - 2300	32 (4")	29.5
33	150 - 3500		32.0
34	200 - 4600		65.0
35	230 - 5750		92.5

**Table 5: Operating Limits, All Metal Flow Meter, Small Body**

BODY SIZE & DESCRIPTION	MAXIMUM NON-SHOCK WORKING PRESSURE, PSIG @ °F								CONNECTION SIZE
	0°F	70°F	300°F	350°F	400°F	450°F	500°F	600°F	
All Stainless	1000	1000	1000	990	970	950	930	900	Up to 3/4"
All Stainless	800	800	800	790	780	770	760	750	Up to 2"

**Table 6: Operating Limits, All Metal Flow Meter, Large Body**

BODY SIZE & DESCRIPTION	MAXIMUM NON-SHOCK WORKING PRESSURE, PSIG @ °F							CONNECTION SIZE
	To 100°F	150°F	200°F	250°F	300°F	350°F	400°F	
All Stainless	400	400	400	400	400	375	350	2" to 4"

**N.R. = NOT RECOMMENDED**

\* OPERATING LIMITS GIVEN ARE BASED ON WATER OR AIR. FOR MORE SEVERE SERVICE, CORROSIVES, AND OTHER MEDIA AND/OR ENVIRONMENTAL FACTORS, AN ADDITIONAL CORRECTION FACTOR DOWN-RATING THESE LIMITS MAY BE REQUIRED. LIMITS ARE BASED ON TESTING AND PRACTICAL EXPERIENCE. POSSIBLE EXTREME APPLICATION CONDITIONS CANNOT BE FORESEEN. THUS, DATA IS OFFERED ONLY AS A GUIDE. IT IN NO WAY CONSTITUTES A SPECIFIC RECOMMENDATION OR WARRANTY EXPRESSED OR IMPLIED.

**Troubleshooting**

SYMPTOM	USUAL CAUSE	SUGGESTED REMEDY
<b>FLOAT HANG-UP</b>	Usually caused by particles, sludge, etc. (including failure to remove the plastic tubing used to block meter float during shipment) inside the core tube and/or measuring tube holding float. A bent float shaft or guide rod (usually caused by careless disassembly or violent surges) may also be causing float to stick.	Remedies include tapping the meter gently to temporarily dislodge the float, but if the problem reoccurs, meter should be disassembled and cleaned, and/or float shaft or guide rod straightened. If hang-up caused by sludge or pipe scale, clean lines and install a filter or other form of cleaner in supply line.
<b>FLOAT BOUNCE</b>	Caused by pumping/compressor surges or other pulsation sources, loose valve disks or similar mechanical components, extreme violation of inlet piping recommendations, or for gas applications, harmonics commonly found in systems with low pressure, low density gas.	Modification of piping, such as addition of a desurger, receiver, accumulator, vibration eliminators, loops, hoses, etc. between the source and meter should remedy the problem. Severe vibration may ultimately damage the meter, and should be avoided. If "bounce" seems to be from some other source, or shocks such as "water hammer" (a potentially dangerous condition), discontinue using the meter and contact FLO-CORP.
<b>APPARENT FALSE READING, GAS METERS</b>	Gas density not according to calibration data( different pressure, temperature, gas, etc), high water vapor content, saturated gas going into vapor or condensation phases, partially clogged core tube slot or foreign matter interfering with float movement, and/or violation of piping recommendations at high flow velocities.	Remedies include checking meter pressure (FLO-CORP can install a pressure gauge on the meter) & temperature, determining actual gas mixture density & correcting with appropriate formulae in this bulletin. Modifying inlet piping, relocating meter to point of higher temperature and/or lower pressure to eliminate vapor or condensation phase effects, and/or cleaning the meter (install filter or other form of cleaner if dirt repetitive problem) may also be required. If accuracy still questioned, return core tube/float assembly to FLO-CORP for calibration check.

<p><b>APPARENT FALSE READINGS, LIQUID METERS</b></p>	<p>Liquid density not according to calibration data (different temperature or new liquid mixture), excessive dissolved or suspended solids or gases, partial clogging of core tube slot or foreign matter interfering with float movement, or viscosity levels above the meter's immunity index (V.I.C.).</p> <p>NOTE: If the MEMFlo meter is suspected of giving false readings, and none of the causes mentioned is found, please advise MEMFlo as to the method used in determining the suspected flow "error." Each MEMFlo flow meter is individually calibrated by traceable methods, and carefully inspected. There may be some error in checking the MEMFlo meter against another standard.</p>	<p>By determining the actual density (due to changes in mixture, temperature, etc.), the correction formula may be applied. If dissolved gases are in the liquid, some elimination means should be provided on the supply side (also recheck all piping, as improper seals at connection points are common sources of air in the liquid.) If the metered liquid is near the boiling point producing partial "flash gas" at the meter, relocate the meter to point of lower temperature and/or higher pressure, or cool lines and/or increase system pressure. Note: It is potentially dangerous to meter near the "flash point" of any fluid, and this practice should be avoided. Consult FLO-CORP for recommendations. The previous recommendations regarding cleaning the meter and/or filtration will also solve problems due to dirt. If metering liquids with high viscosities, consult FLO-CORP (may require special calibration). If none of these causes seem to be present, return meter core tube/float assembly to FLO-CORP along with the application data.</p>
<p><b>APPARENT METER READING MIGRATION (reading changes but flow appears constant)</b></p>	<p>Frequently caused by use of soft disc type valves, which may need to be replaced with a valve more suited to flow control. Can also be indicative of changing fluid conditions (density, viscosity, etc.) Problems with other elements of the flow system, including leaks, clogged filters, pump/compressor wear, etc. may first appear as a change in meter reading-one of the functions of a flow meter.</p>	<p>Verifying the proper fluid conditions are known and applying correction formulae as needed will remedy problems associated with changing fluids. Cleaning, servicing, and replacement and/or repair of other system components may be required.</p>
<p><b>LEAKAGE</b></p>	<p>If at the junction of the body and measuring tube, it is indicative of either (a) damaged O-Ring (most common); (b) damaged measuring tube; or (c) damage to the gland section of the body. It may also be caused by improper reassembly of the flowmeter in the field.</p> <p>If there is leakage at the pipe connections to the meter, it is probably caused from over-tightening pipes on a prior installation (or the initial installation, particularly with PVC or CPVC flow meters).</p>	<p>Replace any damaged parts immediately, using the proper assembly procedures indicated in this instruction and the assembly detail drawings.</p> <p>Remove the body and inspect for damage--if none is visible, check pipe threads, reapply proper thread lubricant/sealant, and reinstall. If leak persists, replace meter body.</p>

All MEMFlo flow meters are hydrostatically pressure tested before they are shipped. FLO-CORP encourages you to contact your FLO-CORP representative or the factory with any questions regarding the proper installation and operation of our flow meters.



# Ordering Information

## FLO-CORP MODEL NUMBER BUILDER

For Assistance Call **877.356.5463**

Use the diagram below, working from left to right to construct your FLO-CORP Model Number.  
Simply match the category number to the corresponding box number.

**Example: MFAM-LS-2924-TCK**

*MEMFlo MFAM Flow Meter for liquid service, zinc phosphate, xylan 1052 coated steel, 10-200 GPM Liquid, 3" Connection Size, Female NPT Connection Type, Corrosive Resistant Scale, Kalrez O-Ring with No Additional Options*

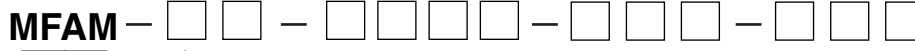

**MFAM**

**Service (1)**

- L) Liquid
- G) Gas

**Meter Material (2)**

- S) T-316 Stainless Steel (1/2" to 1 1/2" small body)  
Zinc Phosphate, Xylan 1052 Coated Steel  
(2" to 4" Large Body)

**Capacity Designator (3)**

	GPM Liquid	SCFM Gas
00)	0.04 - 0.8	0.5 - 10.2
01)	0.06 - 1.2	0.6 - 14
02)	0.08 - 1.64	1 - 20
03)	0.1 - 2.6	1 - 26
04)	0.15 - 3.8	1 - 35
05)	0.2 - 5.4	2 - 50
06)	0.2 - 7	3 - 70
07)	0.2 - 10	4 - 85
08)	0.6 - 14	6 - 125
09)	0.5 - 23	6 - 160
10)	0.5 - 11	4 - 260
11)	0.7 - 15	1.5 - 25
12)	1 - 21	1 - 31
13)	0.5 - 35	2 - 40
14)	1 - 50	3 - 70
15)	2 - 70	4 - 100
16)	3 - 90	5 - 140
17)	4 - 120	5 - 175
18)	NA	6 - 250
19)	NA	2 - 310
20)	NA	7.5 - 390
21)	NA	10 - 510
22)	NA	35 - 750
23)	NA	20 - 1000
24)	3 - 70	30 - 750
25)	3 - 100	40 - 1000
26)	6 - 150	50 - 1750
27)	3 - 100	40 - 1000
28)	6 - 150	50 - 1750
29)	10 - 200	100 - 2300
30)	14 - 300	150 - 3500
31)	5 - 100	50 - 1200
32)	10 - 200	100 - 2300
33)	14 - 300	150 - 3500
34)	15 - 400	200 - 4600
35)	20 - 500	230 - 5750

**Connection Size (4)**

04)	1/2"
06)	3/4"
08)	1"
12)	1 1/2"
16)	2"
16)	2"
20)	2 1/2"
24)	3"
32)	4"

**Connection Type (5)**

- T) Female NPT Threaded
- F) ANSI 150lb Flange
- X) Special Connection

**Scaling Options (6)**

- C) Vinyl
- P) Percent of Flow
- M) Multiple Scales
- X) Other

**O-Ring Material**

- B) Buna-N
- E) EPDM (Ethylene Propylene)
- K) Kalrez
- N) Neoprene
- S) Silicone
- T) Teflon
- V) Viton

**Additional Options (7)**

- N--) None
- GP#) Gauge Port
- GS#) T-316 Pressure Gauge
- TR-) High-Temp Raceway

**Ordering Notes:**

- (1) Select the best configuration based on your requirements.
  - (2) Stainless bodies available in large body sizes. Please consult factory.
  - (3) Sizing is based on GPM Liquid, Sp. Gr. = 1.00 or SCFM Air @ 100 psig 70° F
  - (4) Connection Size is based on Capacity - Colors must match to ensure compatibility.
  - (5) If you require a Special Connection (X), please consult factory with requirements.
  - (6) For digital or custom scaling, select Other (X) and note the following requirements:  
Digital Display: Consult Factory for best option  
Custom Scale: Requires Flow Application (Consult Factory)
  - (7) To package the MFT2 flow transmitter see MFT2 data sheet model number builder
- Note:** Match color with connection size.