



MEMFlo™ MFAM

ALL METAL FLOW METER



DESCRIPTION

MEMFlo™ MFAM All Metal Flow Meters are simple, accurate, meters for use in a wide range of industrial liquid and gas applications. These meters have an excellent tolerance to suspended solids and measure flow to one percent accuracy. With an all metal design, these meters are ideal for high pressures, high temperatures, steam, dirty fluids, and harsh service environments. MFAM All Metal Flow Meters use an internal magnet to carry an external indicator in a non-wetted enclosure. And they can be supplied with the MFT2™ 2-Wire Transmitters for flow rate and total. Additionally, these meters can be supplied with a high temperature indicator option for service up to 600°F.

FEATURES & BENEFITS

- All metal construction for high pressures & temperatures.
- Ideal for steam service, very dirty fluids, and harsh service environments.
- Internal magnet carries external indicator in a non-wetted enclosure.
- Excellent tolerance to suspended solids.
- Extended flow ranges averaging 30 to 1.
- No springs, cams, or seals to wear out.
- Standard 1/2" to 4" female NPT connections or optional flanges. Pipe adapters may be used for other sizes without affecting accuracy.
- Flows to 500 GPM liquids or 5750 SCFM gases.
- 360° rotation of scale. Special scales for other units or fluids & multiple scaling offered.
- Options include MFT2™ 2-Wire Flow Transmitter, Alarms, Pressure Gauge on Meter and Oxygen cleaning.
- Economically priced.

TECHNOLOGY

MEMFlo™ MFAM All Metal Flow Meters are patented variable area flow meters using the volumetric principle of flow measurement. These SupraFlo™ meters consist of five main parts including the body/measuring tube, core tube, float assembly, scale, and pitot tube. The meter is not a glass tapered tube, rather the media enters the meter vertically at the bottom inlet port and flows upward into the core tube. Then the media flows horizontally through the core tube slot and exits the meter through the side outlet port. During this process the media lifts the float assembly in the core tube in direct proportion to the rate of flow. The slotted core tube design gives the meter an excellent tolerance to suspended solids and there are no springs, cams, or dynamic seals to wear out.

The external indicator displays flow rate. The MFT2™ Flow Transmitter has an analog 4-20mA or 0-5, 0-10 VDC output to a remote display, PLC, Recorder, or other customer-supplied receiver.

Using a simple and rugged design, the MEMFlo All Metal Flow Meters measure to 1% accuracy.

SPECIFICATIONS

Accuracy	± 1% of 100% flow rate
Repeatability	1/2" to 1-1/2": +/- 1/4% of indicated flow rate 2" to 4": +/- 1/2% of indicated flow rate
Rangeability	30 to 1 average
Materials	1/2" to 2" Small Body: T-316 Stainless Steel 2" to 4" Large Body: Zinc Phosphate, Xylan 1052 coated steel with all stainless internals

Pressure Rating	Up to 1000 psig
Temperature Rating	Up to 600°F (pressure ratings decrease at higher temperatures).
O-Rings	Buna N standard; Viton, Ethylene-Propylene (EPR), Silicone, Neoprene, Teflon, Geothermal EPR (600° steam), and Kalrez optional.
Scales	Standard direct reading (GPM or LPM Liquid, Sp. Gr. = 1.00 or SCFM Dry Air @ 100 psig, 70°F.) or percentage scale. Special scales for other flow units or media conditions, or mylar scales for corrosive environments are available. Scale length is approximately 3.2" for small bodies (1/2" to 2") and 5.2" for large bodies (2" to 4").

DIMENSIONS

Small Body

Note: Please Consult Factory for Special Requirements

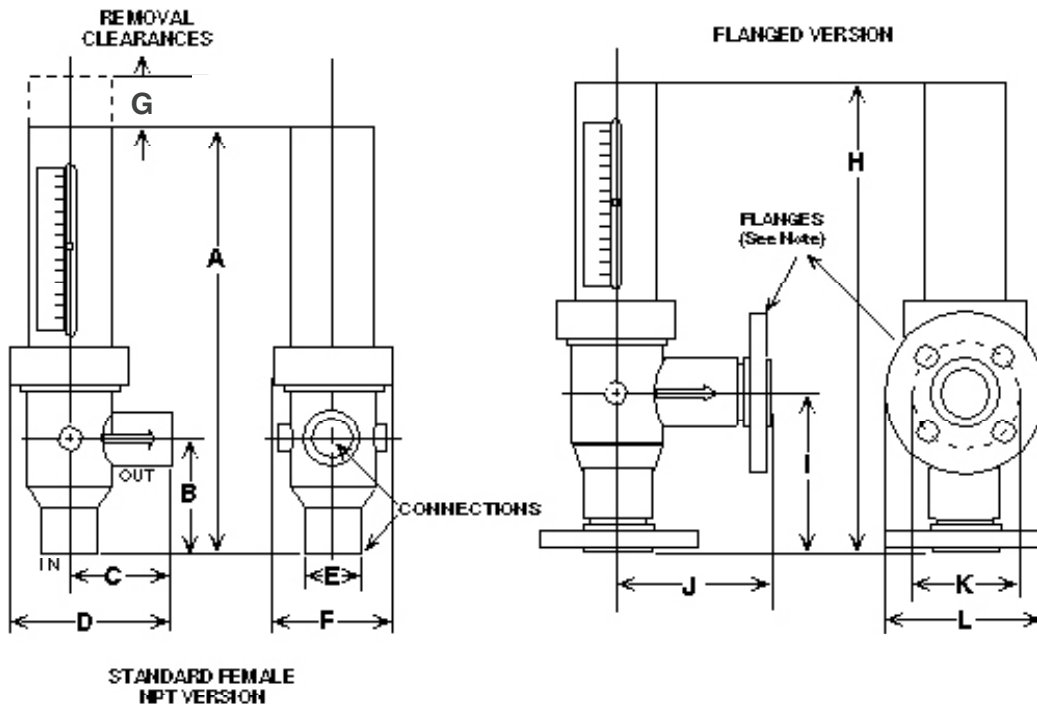

BODY MATERIAL	A	B	C	D	E	F	G	Female NPT
All Stainless	11.20	2.81	2.68	4.03	1.35	2.75	3.00	Up to 3/4"
All Stainless	15.64	4.53	3.71	5.70	2.48	4.01	5.00	Up to 2"

BODY MATERIAL	H	I	J	K	L	150lb Flange
All Stainless	11.64	5.92	3.56	2.75	3.88	Up to 3/4"
All Stainless	17.03	5.92	4.96	3.88	5.00	Up to 2"

Note: All dimensions are in inches, with a tolerance of ±0.03" on threaded models, ±0.20" on flanged units.

Large Body

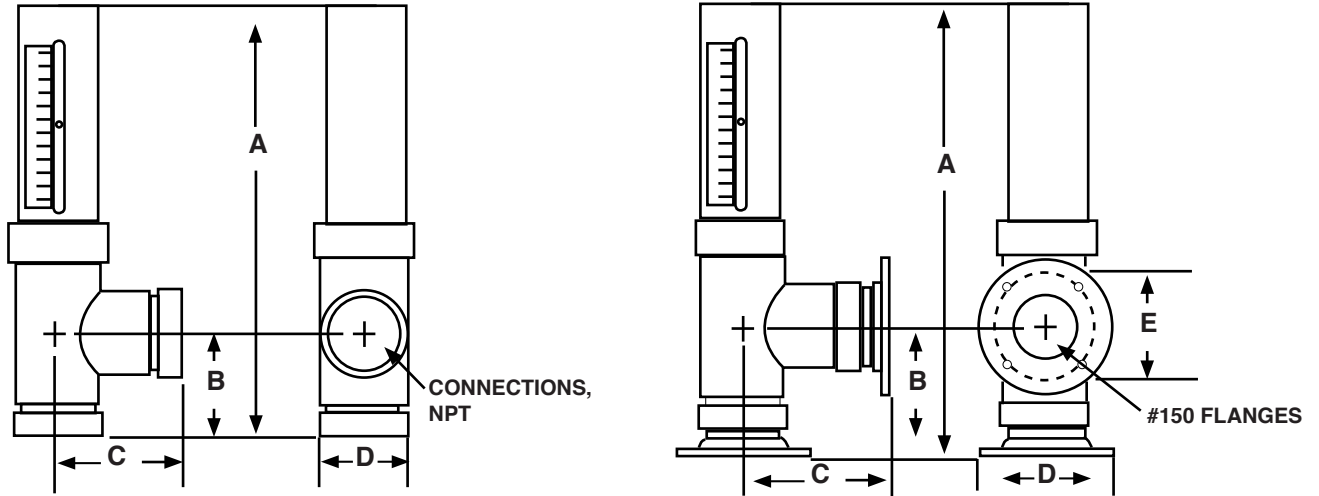

BODY & MEASURING TUBE DESCRIPTION	A	B	C	D	E	Female NPT
Stainless	20.23	6.38	5.38	3.63	NA	2"
Stainless	20.85	6.38	5.38	3.36	NA	2 1/2"
Stainless (150 GPM/1750 SCFM)	22.35	7.50	6.00	4.25	NA	3"
Stainless (200 GPM/2300 SCFM)	25.35	7.88	6.38	4.50	NA	
Stainless	26.85	8.63	7.13	5.56	NA	4"

BODY & MEASURING TUBE DESCRIPTION	A	B	C	D	E	150lb Flange
Stainless	20.73	6.28	6.88	6.00	4.75	2"
Stainless	21.35	6.88	6.88	7.00	5.50	2 1/2"
Stainless (150 GPM/1750 SCFM)	22.60	7.75	7.75	7.50	6.00	3"
Stainless (200 GPM/2300 SCFM)	25.60	8.13	8.13	7.50	6.00	
Stainless	28.10	9.88	9.88	9.00	7.50	4"

Note: All dimensions are in inches, $\pm 0.05"$. Subject to change without prior notice.

MFT2™ TWO-WIRE FLOW TRANSMITTER

MOUNT TO YOUR VOLUMETRIC FLOW METER
FOR OUTPUT FLOW RATE

DESCRIPTION

The MFT2™ two-wire flow transmitter accurately calculates and outputs flow rate. Compatible with any MEMFlo variable area flow meter, MFT2™ combines FLO-CORP's time-proven variable area technology with a high tech processor and solid state circuitry. Each device includes an analog output that can be configured for 0-5 VDC, 0-10 VDC, or 4-20 mA current loop. Typical applications include pump flow output, compressed air consumption, cooling flow monitoring, steam flow usage/optimization and combustion gas metering.

FEATURES & BENEFITS

- Non-contact sensor electronic
- Electronic signal conditioning circuit
- 3 output modes: 4-20mA, 0-5 VDC or 0-10 VDC
- Proportional analog output - two-wire, 4-20mA
- Designed to slip over any standard measuring tube
- Pre-calibrated from the factory for fast installation and start-up



SPECIFICATIONS

General	
Process Temperature	F: -20° to 240° C: -29° to 116°
Ambient Temperature	F: -20° to 158° C: -29° to 70°
Environmental	Humidity: 0-90% non-condensing
Accuracy	±1% 0.25% rate
Repeatability	±0.10% rate
Electrical	
Power Requirements	0.5 VDC Output 10-30 VDC @ 3 wire 0-10 VDC Output 12-30 VDC @ 3 wire 4-20 mA Output loop-powered, 12 VDC - 30 VDC - 2 wire
Power Consumption	25 mA maximum
Analog Outputs	0-5 VDC and 0-10 VDC into 10,000 Ohms minimum; 4-20 mA into 1000 Ohms maximum
Resolution	1:4000
Transmission Distance	4-20 mA limited by cable resistance (4000') 0-5 VDC 1000 feet (330m) maximum 0-10 VDC 1000 feet (330m) maximum
Circuit Protection	Reverse polarity and current limiting
Isolation	Inherently isolated from the piping system
Transient Over-Voltages	Category 3, in accordance with IEC 64
Temperature Drift	50 ppm/°C (Max)
Enclosure Rating	NEMA 4 (IP67) ; NEMA 7



DigaCom™ 2000 Universal Process Display

is a field mount display that provides bright, 6-digit LED indication, internal DC power supply for transmitter power, 4-20mA repeat output and advanced communications. DigaCom features digital push button configuration, simple programming interface and Ethernet communication. This device is well suited for a variety of process applications. Typical applications include level monitoring, analytical measurements, flow, distance monitoring, pressure monitoring, weight/ volume monitoring and temperature monitoring.



DigaLink™ 3.0 Alarm & Monitoring Software

is FLO-CORP's unique Alarm, Configuration and Monitoring Software. This enables users to receive e-mail alerts, configure, and remotely monitor from the convenience of their PC. DigaLink is unique in its communication protocol that utilizes both TCP/IP Ethernet communication and Modbus/RS485 serial communication simultaneously. This advanced software features e-mail alerts, display configuration, datalogging and real-time monitoring from unlimited devices. With DigaLink you can easily setup, monitor and receive e-mail alerts from practically anywhere.



eXmod™ Relay Expansion Module

is a 4-relay output module that connects to the display via RS-485 serial communication (4-wire). It is extremely versatile and can be mounted locally or remotely to allow for a purely distributed system. Display(s) can be mounted in the plant or control panel, while the eXmod can be mounted in the motor control cabinet for reduced cost of control wiring. Additionally, the eXmod's BIG 10 AMP AC/DC rated relays bring added value to your control/alarm monitoring systems.

Ordering Information

FLO-CORP MODEL NUMBER BUILDER

For Assistance Call **877.356.5463**

Use the diagram below, working from left to right to construct your FLO-CORP Model Number.
Simply match the category number to the corresponding box number.

Example: MFAM-LS-2924-TCK

MEMFlo MFAM Flow Meter for liquid service, zinc phosphate, xylan 1052 coated steel, 10-200 GPM Liquid, 3" Connection Size, Female NPT Connection Type, Corrosive Resistant Scale, Kalrez O-Ring with No Additional Options

MFAM — — — —

MFAM — **Service (1)**
L) G)
Meter Material (2)
S) T-316 **Capacity Designator (3)**

	GPM Liquid	SCFM Gas
00)	0.04 - 0.8	0.5 - 10.2
01)	0.06 - 1.2	0.6 - 14
02)	0.08 - 1.64	1 - 20
03)	0.1 - 2.6	1 - 26
04)	0.15 - 3.8	1 - 35
05)	0.2 - 5.4	2 - 50
06)	0.2 - 7	3 - 70
07)	0.2 - 10	4 - 85
08)	0.6 - 14	6 - 125
09)	0.5 - 23	6 - 160
10)	0.5 - 11	4 - 260
11)	0.7 - 15	1.5 - 25
12)	1 - 21	1 - 31
13)	0.5 - 35	2 - 40
14)	1 - 50	3 - 70
15)	2 - 70	4 - 100
16)	3 - 90	5 - 140
17)	4 - 120	5 - 175
18)	NA	6 - 250
19)	NA	2 - 310
20)	NA	7.5 - 390
21)	NA	10 - 510
22)	NA	35 - 750
23)	NA	20 - 1000
24)	3 - 70	30 - 750
25)	3 - 100	40 - 1000
26)	6 - 150	50 - 1750
27)	3 - 100	40 - 1000
28)	6 - 150	50 - 1750
29)	10 - 200	100 - 2300
30)	14 - 300	150 - 3500
31)	5 - 100	50 - 1200
32)	10 - 200	100 - 2300
33)	14 - 300	150 - 3500
34)	15 - 400	200 - 4600
35)	20 - 500	230 - 5750

Connection Size (4)

04)	1/2"
06)	3/4"
08)	1"
12)	1 1/2"
16)	2"
16)	2"
20)	2 1/2"
24)	3"
32)	4"

Connection Type (5)

T) Female NPT Threaded
F) ANSI 150lb Flange
X) Special Connection

Scaling Options (6)

C) Vinyl
P) Percent of Flow
M) Multiple Scales
X) Other

O-Ring Material

B) Buna-N
E) EPDM (Ethylene Propylene)
K) Kalrez
N) Neoprene
S) Silicone
T) Teflon
V) Viton

Additional Options (7)

N--) None
GP#) Gauge Port
GS#) T-316 Pressure Gauge
TR-) High-Temp Raceway

Ordering Notes:

- (1) Select the best configuration based on your requirements.
 - (2) Stainless bodies available in large body sizes. Please consult factory.
 - (3) Sizing is based on GPM Liquid, Sp. Gr. = 1.00 or SCFM Air @ 100 psig 70° F
 - (4) Connection Size is based on Capacity - Colors must match to ensure compatibility.
 - (5) If you require a Special Connection (X), please consult factory with requirements.
 - (6) For digital or custom scaling, select Other (X) and note the following requirements:
Digital Display: Consult Factory for best option
Custom Scale: Requires Flow Application (Consult Factory)
 - (7) To package the MFT2 flow transmitter see MFT2 data sheet model number builder
- Note:** Match color with connection size.