



OPERATING INSTRUCTIONS

CALFLO™ CFNF2 DC THERMAL MASS AIR FLOW SWITCH





Safety Precautions

About This Manual:

PLEASE READ THE ENTIRE MANUAL AND SPECIFICATIONS PRIOR TO INSTALLING OR USING THIS PRODUCT.

This manual includes information on the CalFlo CFNF2 DC Thermal Mass Air Flow Switch: CFNF2-U and CFNF2-S. Please refer to the part number to verify the exact model which you have purchased.

User's Responsibility for Safety:

FLO-CORP provides a wide range of flow and level technologies. While this device is designed to operate in a wide variety of applications, it is the user's responsibility to select a model that is appropriate for the application, install it properly, perform tests of the installed system, and maintain all components. The failure to do so could result in property damage or serious injury.

Wiring and Electrical:

The supply voltage used to power the device should never exceed a maximum of 24 volts DC. Electrical wiring of the device should be performed in accordance with all applicable national, state, and local codes.

Flammable, Explosive and Hazardous Applications:

Flow Switches should not be used with explosive or flammable liquids, which require an intrinsically safe or classified area rating!

Description

The CFNF2 DC Flow Switch is an industrial purpose device that will monitor a variety of air or gaseous applications. The CFNF2 features solid-state switching and is extremely reliable even under the harshest environmental conditions. The CFNF2 features a repeatable alarm, an adjustable set-point from 3 to 32 feet per second, and LED indication of flow. The short housing is intended for use in pipe sizes 1/2" to 1" in diameter and the long housing is recommended for pipe sizes 2" and up.

Specifications

Service	Compatible Gasses
Switching Range	3 to 32 fps (1 to 10 mps)
Factory set-point	10 fps (3 mps)
Pressure	CFNF2-U: 15 psi (1 bar) CFNF2-S: 150 psi (10 bar)
Hysteresis	≤ 30%
Switching Delay	Min. 3 s/ Max. 100 s (depends on set-point adjustment)
Temperature Drift	< 0.5% / K
Supply Voltage	24 VDC ±10%
Residual Ripple	20%
Switching Current	500 mA max.
Repeatability	< 3%
Consumption	Approx. 1W
Starting Override Time	Max. 90 s
Output	PNP Normally Open (closed with flow) PNP Normally Closed (open with flow) NPN Normally Open (closed with flow) NPN Normally Closed (open with flow)
Display	LED for ON or OFF state
Process Temperature	F: -4° to 160° C: -20° to 70°
Ambient Temperature	F: -4° to 160° C: -20° to 70°
Enclosure Rating	NEMA 4 (IP64)
Housing Material	Ultradur (PBTP) or Stainless Steel
Sensor Material	Ceramic with Over Glaze
Weight	CFNF2-U: 0.3 lbs (130 g) CFNF2-S: 0.4 lbs (200 g) without nut
Cable	
Cable Jacket Material	Oilflex
Cable Length	6.5' (2m)

Note: Please Consult Factory for Special Requirements

Dimensions In (mm)

Housing	X	Y
Short	2.5" (64 mm)	3.03" (77 mm)
Long	2.91" (74 mm)	3.42" (87 mm)

CFNF2-U: Ultradur (PBTP) Housing
(Installation with mounting flange)

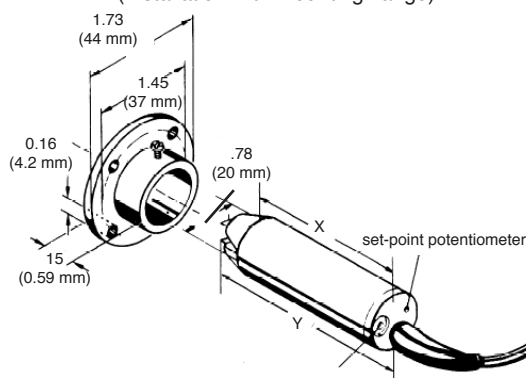

CFNF2-S: Stainless Steel Housing
(installation with union nut)

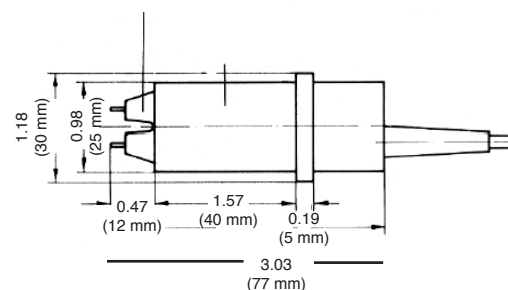

Installation and Instructions

Please read carefully! No liability can be accepted for damage caused by improper use of the CFNF2 Flow Switch.

1.0 Installation

With supplied mounting flange (optional PG 21) or union nut (Type CFNF2-S)

1 Installation Depth

Dependent on duct diameter, min. 0.6 in (15 mm).

2 Flow Direction

Position the probes lengthwise parallel to flow.

Type CFNF2-U

Type CFNF2-S

2.0 Electrical Connection

Ensure that the unit is connected in accordance with the appropriate electrical connection diagram.

Attention: This unit is not short circuit protected!

3.0 Switching Characteristics

3.01 Starting Override Time

The thermal time delay applies to a cold unit, at factory set-point approx. 60 seconds.

3.02 Switching Delay

The time delay of the unit is defined by the rate of change of flow speed relative to the set-point. This time delay is not constant, the faster the change, the shorter the time delay. Depending upon adjustment it varies from 3 seconds to more than 100 seconds.

4.0 LED-Function

Units with normally open switching function:

LED "OFF" - no flow = output, "OFF"

LED "ON" flow = output "ON"

Units with normally closed switching function:

LED "ON" - no flow = output "ON"

LED "OFF" flow = output "OFF"

5.0 Set-point Adjustment

For general applications these units are factory set at an air flow rate of 10 fps (3 mps) and are therefore ready to use without any further adjustment.

5.2 Changing Set-point:

Stable operating condition reached 5 minutes after electrical connection.

5.13 Decrease sensitivity (clockwise)

5.14 Increase sensitivity (counter-clockwise)

The following instruction refer to units with normally open output!

5.2 With no air flow turn adjustment pot. until LED "ON" (This position sets switch=point to zero flow). Slowly turn adjustment pot. until LED "OFF" = most sensitive setting. Further adjustment, max. 18 turns results in least sensitivity.

Attention: 18 turn potentiometer without mechanical end point.

7.0 Monitoring Air Flow Failure

After 5 minutes with no air flow , turn pot. until LED "ON"

7.01 Turn on normal air flow, wait 3 minutes, adjust pot. (counting the turns) until LED, "OFF".

7.02 Turn back half the number of turns at 6.2 = optimum setting, $tr \sim tf$

8.0 Monitoring Lower Flow Limit

8.01 Reduce flow to min. rate at which a signal is required.

8.02 After 5 minutes slowly turn pot. until LED "OFF".

8.03 Increase flow to normal rate, wait 3 minutes, if LED "ON" setting is correct.

8.04 If LED stays "OFF" the flow rate difference is too small. In this case turn slowly until LED "ON".

8.0 Monitoring Upper Flow Limit

8.6 Increase flow to rate at which a signal is required.

8.7 Turn pot. until LED "OFF"

8.8 Wait 5 minutes turn pot. slowly until LED "ON"

8.9 Decrease flow to normal rate. Wait 3 minutes, if LED "OFF" setting is correct.

8.10 If LED stays "ON" the flow rate difference is too small. In this case turn pot. until LED "OFF"

Ordering Information

FLO-CORP MODEL NUMBER BUILDER

For Assistance Call **877.356.5463**

Use the diagram below, working from left to right to construct your FLO-CORP Model Number.
Simply match the category number to the corresponding box number.

Example: CFNF2-U-PNO-S CalFlo™ CFNF2 DC Thermal Mass Air Flow Switch, Ultradur (PBTP) Housing, PNP Normally Open Output, Short Housing

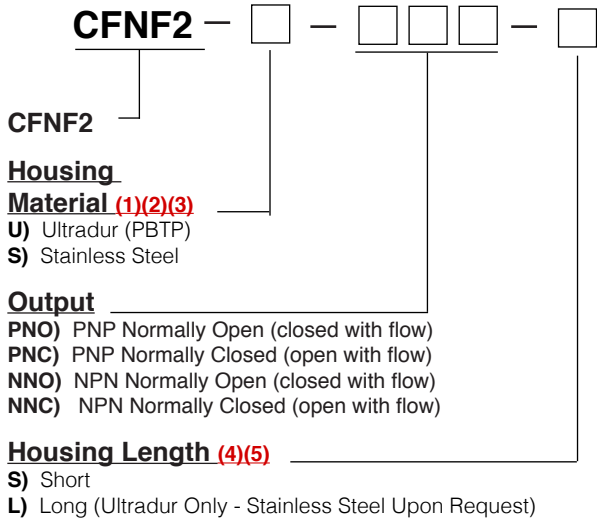

Ordering Notes

- (1) Select the best configuration based on your requirements
- (2) The Stainless Steel unit (CFNF2-S) comes standard with NPT (US) threaded union nut for installation. To special order a BSP (Metric) threaded union nut, place BSP at the end of the P/N: (ie CFNF2-S-PNO-S-BSP).
- (3) For additional mounting options, please contact factory
- (4) Select the short housing for use with pipe sizes " to 1 " in diameter and the long housing for 2" and up.
- (5) Comes complete with 6.5' (2 m) pre-wired cable and manual.