

OPERATING INSTRUCTIONS

CALFLO™ CFAF THERMAL MASS AIR FLOW METER



Installation and Adjustment Instructions

Please read carefully! No liability can be accepted for damage caused by improper use of the CFAF Flow Meter.

Installation

With supplied mounting flange (optional PG 21) or union nut (Type CFAF-S)

Installation Depth

Dependant on duct diameter, min. 0.6 in (15 mm).

Orientation

Position the ceramic sensor elements so that they are parallel to the direction of flow, as illustrated below.

Type CFAF-U

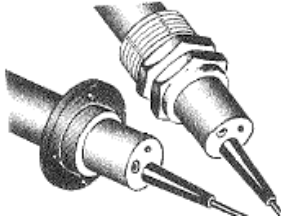

mounting flange

Type CFAF-S

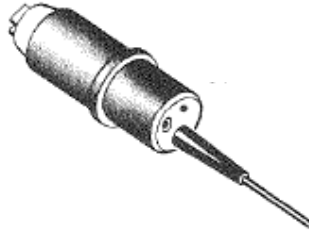

stainless steel casing



Installation Site

Optimal installation is with a straight free run of 5-7 x ID diameter upstream and 3-5 x ID diameter downstream of the meter.

Installation of Type CFAF-U with Mounting Flange

Drill 21 mm hole and 4 screw holes in wall of air-duct.

Secure the mounting flange with the 4 screws provided.

Push the AirFlo into duct and secure by tightening the locking screw on the side of the flange. Sealing lip on flange provides secure fitting.

Alternatively a PG 21 connector may be used (see "items delivered").

Metal PG 21 fittings are modified by the manufacturer.

Modification is indicated by a "1" on the fitting's hexagon nut.

Installation of Type CFAF-S

Fit the O-ring over the front of the CFAF and push back to the flange. Insert the CFAF into the previously mounted 1" fitting and secure with the union nut provided. The fitting (available as separate accessory) is designed to ensure the optional insertion depth of the CFAF.

Powering Up

Connect the CFAF to 24 VDC as in connection diagram and wait approx. 5 minutes before commencing adjustment.

Initial State

The Zero point potentiometer P2 is adjusted ex works to 4 mA.

The range potentiometer P1 is adjusted to the extreme clockwise position.

Where ex works adjustment of measurement range has been requested, both potentiometers are sealed with silicone.

Adjustment is carried out under manufacturer's test rig conditions. Under different installation conditions on site, deviations in output signal may be possible.

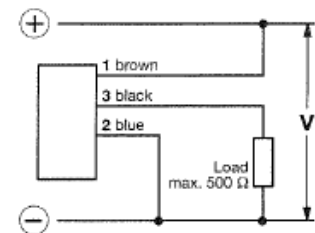

N.B.
18-turn potentiometers are employed with no mechanical end point

Potentiometer:
P1 (measurement range)
P2 (zero point)



Adjustment Procedure

Zero point adjustment in stationary medium:

Adjust potentiometer P2 after 5 minutes so that $I_a = 4 \text{ mA}$.

ie: if $I_a > 4 \text{ mA}$ turn pot. P2 slowly to the **left**

if $I_a < 4 \text{ mA}$ turn pot. P2 slowly to the **right**.

left (counter-clockwise)

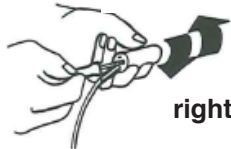

right (clockwise)

Adjustment of measurement range at the max. flow rate which is to correspond to 20 mA output:

After 3 minutes at max. flow-rate turn pot. P1 until $I_a = 20 \text{ mA}$.

ie: If $I_a > 20 \text{ mA}$ turn pot. P1 slowly to the **right**

If $I_a < 20 \text{ mA}$ turn pot. P1 slowly to the **left**

Check Zero Point and Range

Check zero and range adjustments as in points 4.1 and 4.2 and correct any discrepancies as necessary.

LED indicates operation within measurement range, and switches off when flow speed is out of the adjusted range ($I_a > 20 \text{ mA}$).

Electrical Data	
Voltage Supply	24 VDC \pm 30%
Current Consumption	Approx. 800 mW - 1.3 W (max. flow speed)
Output Current	4 - 20 mA
Resistive Load	0 - 500 Ohm
Adjustment of Measurement Range By means of potentiometer with small screwdriver. A green LED indicates operation within the adjusted measurement range. The LED is extinguished when this range is exceeded.	

Mechanical Data	
Material	Sensor probe: Ceramic with overglaze Housing: Ultradur (PBTP)
Medium Temperature Range	-20° C to +70° C (-4° F to +160° F)
Ambient Temperature	-20° C to +70° C (-4° F to \pm 160° F)
Electrical Connection	2 m moulded oilflex cable / 3 x 0.5 mm ²
Protection Standard	IP64
Mass	130 g

Dimensions

Housing	X	Y
Short	2.6" (65mm)	3.1" (79 mm)
Long	3" (75mm)	3.5" (89 mm)

CFAF-U_: Ultradur (PBTP) Housing

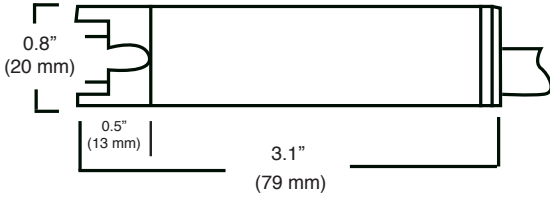

Weight: 130 grams
(0.3 lbs)

CFAF-S_: Stainless Steel Housing (installation with union nut)

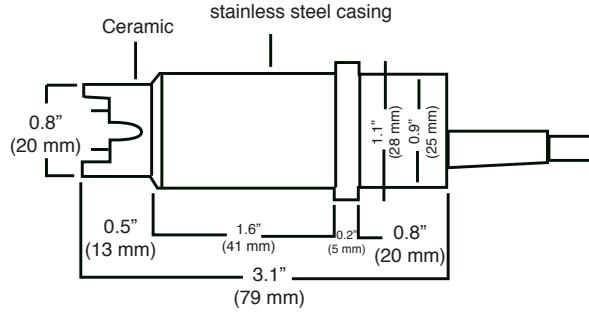

Weight: 200 grams (0.41 lbs) w/o union nut
Union Nut: 127.3 grams (0.3 lbs)

Mounting Flange

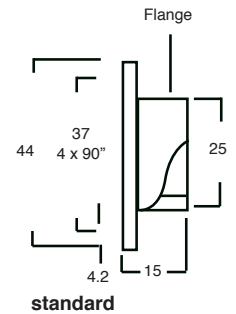

Ordering Information

FLO-CORP MODEL NUMBER BUILDER

For Assistance Call **877.356.5463**

Use the diagram below, working from left to right to construct your FLO-CORP Model Number.
Simply match the category number to the corresponding box number.

Example: CFAF-U-02-S CalFlo CFAF Thermal Mass flow meter with ultradur housing, 0 to 65 fps measuring range, short housing length

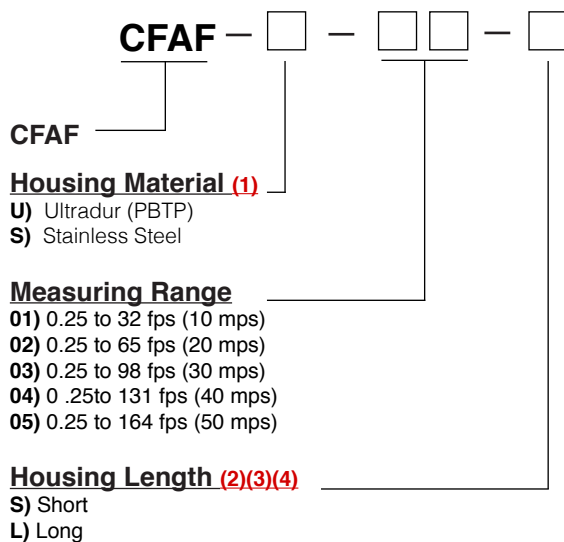

Ordering Notes:

- (1) Select the best configuration based on your requirements.
- (2) Select the short housing for use with pipe sizes 1/2" to 1 1/2" in diameter and the long housing for 2" and up.
- (3) For additional mounting options, please contact factory
- (4) Comes complete with 6.5' (2m) pre-wired cable and manual